

## 6. Roof section to uprights

Fix the L-brackets to the uprights using 2 x 40mm screws per bracket. Lift roof onto uprights so that rebates in the roof rafters rest on the uprights, secure roof to L-bracket using 2 x 40mm screws per bracket.

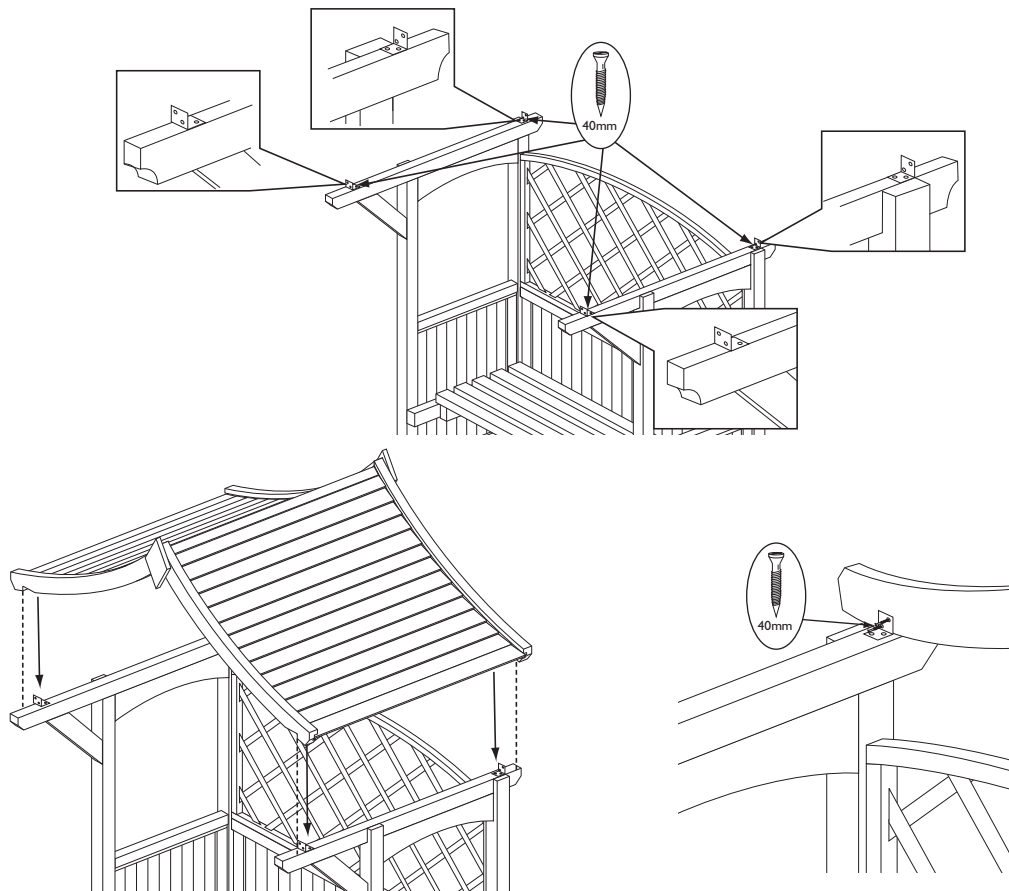

## Safety information

### IMPORTANT, RETAIN FOR FUTURE REFERENCE: READ CAREFULLY

When the side tables are put in the raised position, ensure they are locked in place by turning the turn buttons.

When used as a Barbecue Station, the barbecue should not be left unattended.

Periodically check all fastenings for tightness

For domestic use only

If in doubt of any aspect regarding the assembly, use or safety of your Arbour please contact us:

**Help Line: (Normal Office Hours) 01829 261 121**

**Email: support@rowgar.co.uk**

ROWLINSON GARDEN PRODUCTS LIMITED  
Green Lane  
Wardle Nr. Nantwich  
Cheshire  
CW5 6BN  
[www.rowgar.co.uk](http://www.rowgar.co.uk)

We constantly improve the quality of our products, occasionally the components may differ from the components shown and are only correct at time of printing. We reserve the right to change the specification of our products without prior notice.

2016 © Rowlinson Garden Products Ltd

## BBQ Party Arbour

## English SSI4IE

### Assembly Instructions

#### Before assembly

- We recommend that time is taken to read the instructions before starting assembly, then follow the easy step by step guide. The instruction sheet is only a guide to the assembly. Certain items may not be shown to scale.
- Check all components prior to assembly
- This product should be assembled by no less than two people.
- Never attempt to erect the assembly in high winds.
- Drill all components where indicated.



#### Recommended tools for assembly

- Cross head screw driver
- Drill with 3mm diameter drill bit
- 13mm Spanner

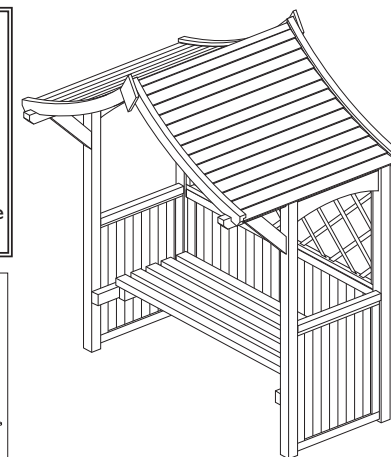
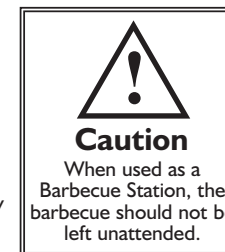

No.	Components	Qty.
1	Seat back	1
2	Seat	1
3	Left upright	1
4	Right upright	1
5	Upright top rail	2
6	Upright top rail support	2
7	Lattice back panel	1
8	Roof slat sections	4
9	FR/BL* roof rafters	2
10	FL/BR* roof rafters	2
11	Centre roof rafter	2
12	Roof coverstrips	1
13	Finials	2

\*FR/BL = Front right/back left  
FL/BR = Front left/back right

No.	Fixing kit	Qty.
14	Metal L-brackets	6
15	70mm screws	8
16	60mm screws	12
17	40mm screws	54
18	100mm Bolts	2
19	Nuts	2
20	Washers	2

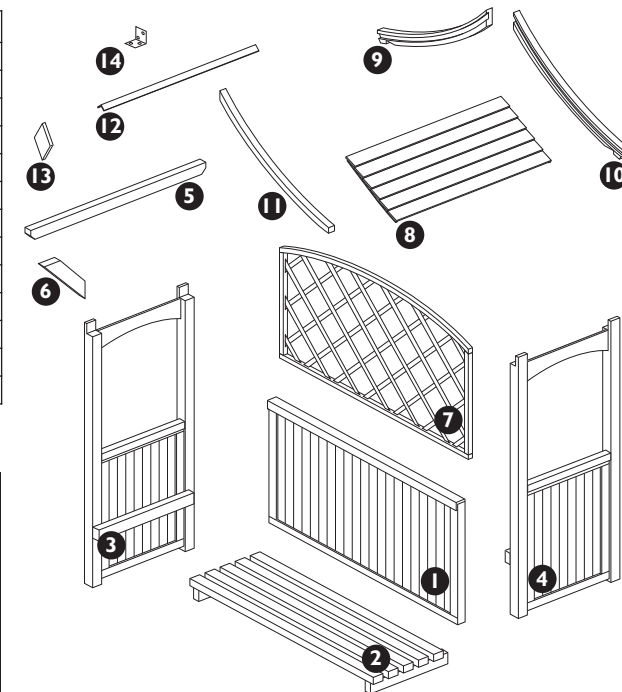

### 1. Seat back to uprights

Drill the back panel as shown in the diagram at both ends. Position back panel between the uprights as shown. Screw through the drilled holes into the uprights using 4 x 70mm screws.

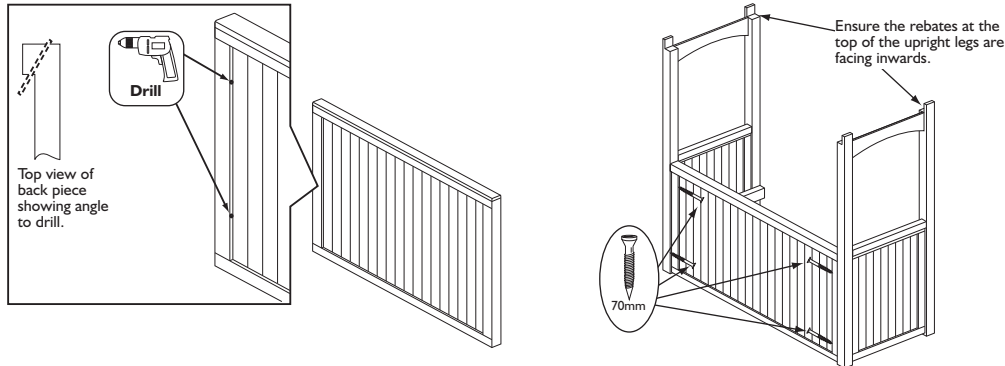

### 2. Upright top rails and lattice back panel

For each upright position an upright top rail to the rebates at the top of the legs as shown. Secure in place using 2 x 60mm screws per leg. secure a top rail support to the underside of the rail and the front leg of the upright using 2 x 60mm screws per support as shown. Place the trellis back piece between the uprights so it rests on the seat back. Screw from inside of the lattice into the uprights using 2 x 70mm screws at each end.

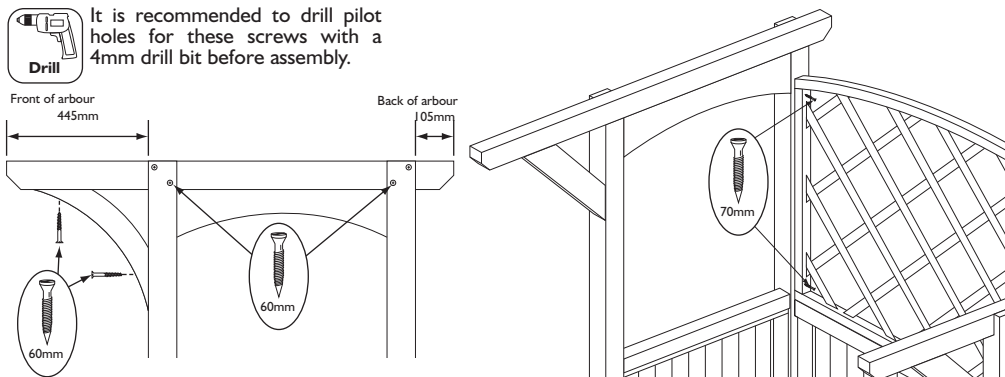

### 3. Seat

Lift the side panels of the uprights and sit the metal supports into the metal brackets on the seat bearers. Position the seat onto the bearers. From the side of the arbour push 1 x 100mm bolt through each hole at the back of the seat bearer and seat. Secure with a nut and washer. Secure the other side in the same way.

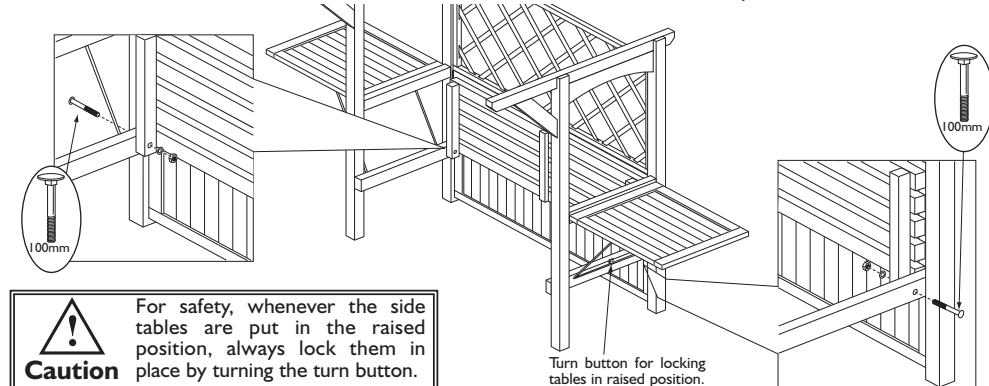

### 4. Roof section assembly

Bend two roof slat section and fit it into the rebates of two bearers as shown below. Secure each bearer using 2 x 40mm screws, screw through the top of the bearer into the slats. Position a centre roof rafter in the middle of the roof section and secure using 2 x 40mm screws, screw through the roof slats into the centre rafter. Create a second roof section in the same way.

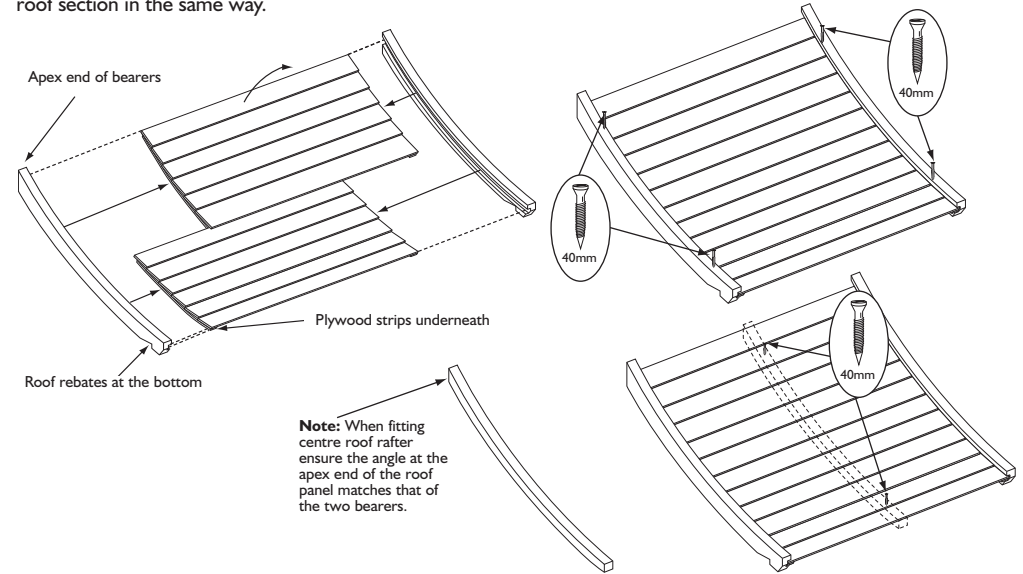

### 5. Roof assembly

On one roof section attach an L-bracket to the underside of each roof bearer at the apex end using 2 x 40mm screws per bracket. Evenly rest the second roof section against the first and attach using 2 x 40mm screws through the L-brackets. Drill 4 holes in each finial. Centre finial so it overlaps both roof bearers and secure using 4 x 40mm screws per finial. Drill two holes at each end and two in the middle of the cover strip as shown. secure the coverstrip on the roof ridge using 6 x 40mm screws.

