

Keswick Arbour

English SS286

Help Line (Normal Office Hours) 01829 261 121

Assembly Instructions

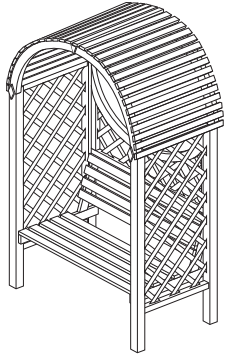

Before assembly

- We recommend that time is taken to read the instructions before starting assembly, then follow the easy step by step guide. The instruction sheet is only a guide to the assembly. Certain items may not be shown to scale.
- Check all components prior to assembly
- Drill all components where indicated.
- This product should be assembled by no less than two people.
- Never attempt to erect the assembly in high winds.



Recommended tools for assembly

- Cross head screw driver
- Drill with 2mm diameter drill bit
- Step Ladder

No.	Components	Qty.
1	Seat	1
2	Seat back	1
3	Back lattice	1
4	Uprights	2
5	Roof rafter (with dowels)	2
6	Roof rafter	2
7	Roof slat sections	2
8	Diamond finials	4
9	Triangular finials	2

No.	Fixing kit	Qty.
10	Flat brackets	4
11	60mm screws	24
12	40mm screws	12
13	25mm screws	16
14	40mm nails	60

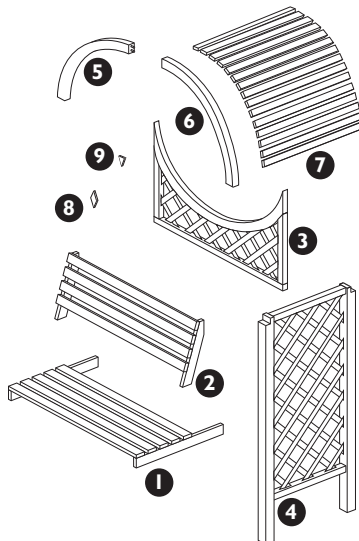

1. Seat to uprights

Drill four holes in each seat slat bearer as shown in the diagram. Position the seat between the two uprights, 345mm from the bottom of the upright. Secure through the drilled holes into the upright legs using 8 x 60mm screws.

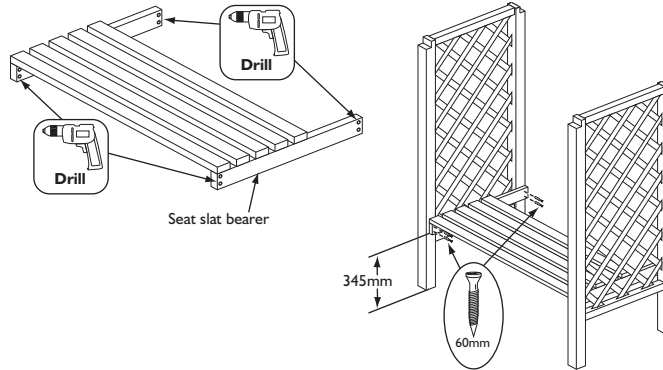

2. Seat back to uprights

Drill four holes in the seat back as shown in the diagram. Place the seat back on the seat between the two uprights. Secure through the drilled holes into the legs of the uprights using 4 x 60mm screws. Attach the seat back to the seat bearer using a flat bracket and 4 x 25mm screws at each side.

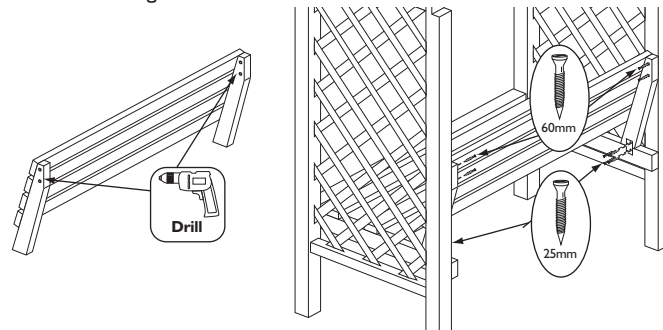

3. Back lattice to uprights

Drill four holes in the back lattice as shown in the diagram. Sit the back lattice on the top of the seat back. Secure through the drilled holes into the legs of the uprights using 4 x 60mm screws

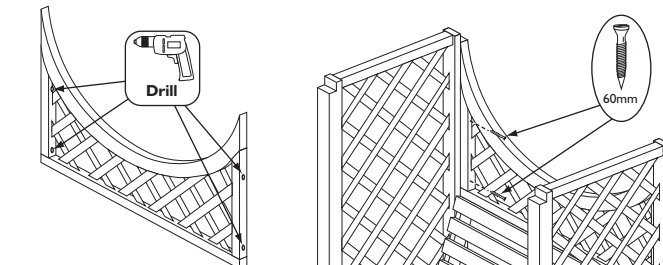

4. Roof rafter Assembly

Slot together one of each of the rafters using the pre-fitted dowels. Join on the back using a flat bracket and 4 x 40mm screws. Drill two holes in a triangular finial. Secure to the front of the rafters centrally over the join using 2 x 40mm screws. Create a second rafter section in the same way.

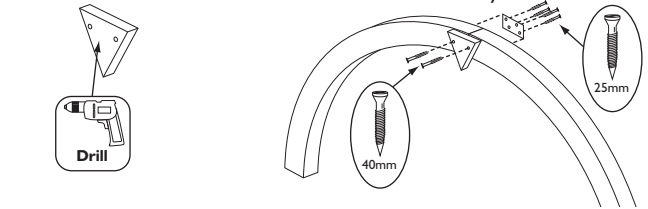

5. Roof to uprights

Lift the rafter sections onto the rebates of the uprights. Drill two holes at each corner of the roof as shown in the diagram, then secure the roof to the uprights using 2 x 60mm screw per corner. Drill two holes in each diamond finial. Secure the finials over the joins between the rafter and the uprights using 2 x 40mm screws per finial.

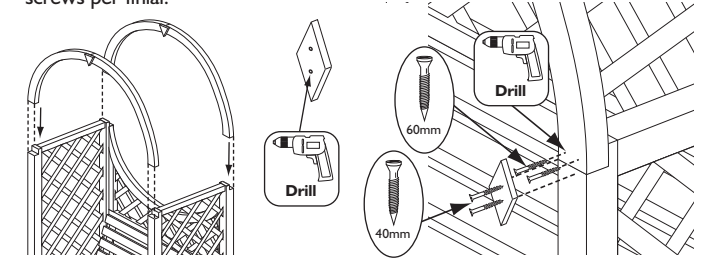

6. Roof slats

Evenly spread the roof slats over the rafters and secure using 2 x 40mm nails per slat, nail through the slats and into the rafters.

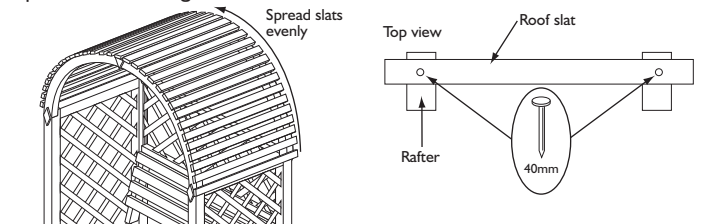

**IMPORTANT: RETAIN FOR FUTURE REFERENCE
READ CAREFULLY**

Periodically check all fastenings for tightness
For domestic use only

We constantly improve the quality of our products, occasionally the components may differ from the components shown and are only correct at time of printing. We reserve the right to change the specification of our products without prior notice.

2012 © Rowlinson Garden Products Ltd