

6. Roof felt

Lay the roofing felt on the roof with an overhang all round. Fold the felt down at the front and secure using 10 x 10mm felt nails to the felt batten. Tension the felt over the roof and fold down at the back and secure to the back panel using 10 x 10mm felt nails. Dress down each end of the felt and secure to the side panels using 8 x 10mm felt nails per end. Once the felt is secure trim of any excess felt.

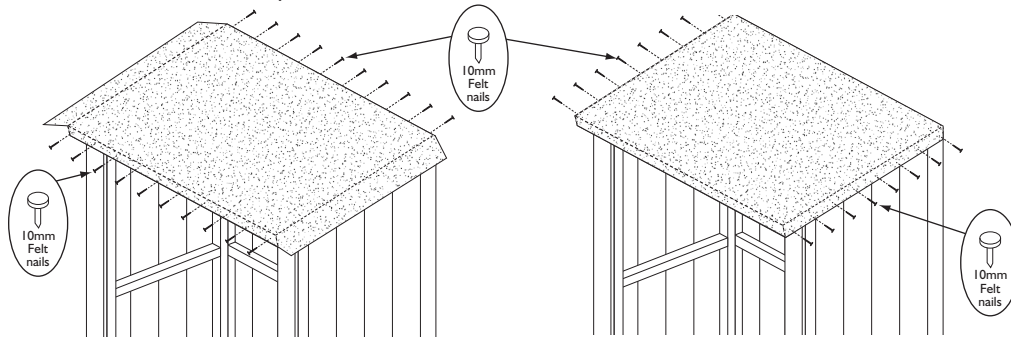

7. Bargeboards

Attach a side bargeboard to each side ensure the top and front edges are flush with the roof line and secure each board in place using 4 x 30mm nails as shown. Attach the front bargeboard to the front of the roof make sure it is flush to the roof line using 4 x 30mm nails.

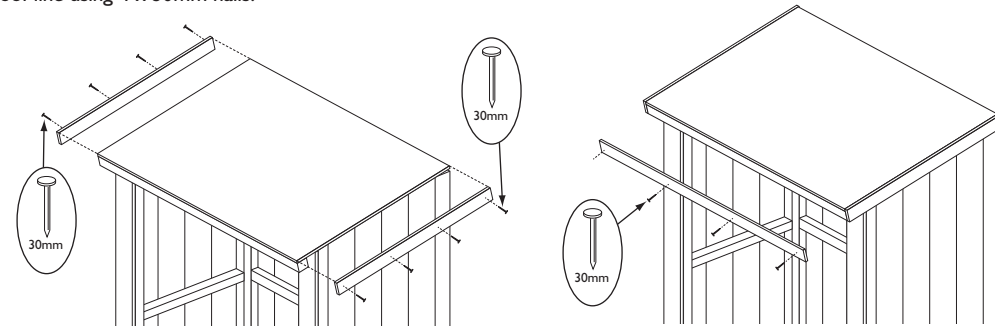

Important information

To **VALIDATE** the guarantee: adequate provision must be made to ensure ground contact is avoided and air is able to circulate underneath the building. The building **MUST** be erected on pressure treated wooden 50mm x 50mm or similar bearers (**These are not supplied in the kit**). The heritage buildings come ready painted, the building must be properly **TREATED ANNUALLY** with a recognised external wood preserver. This can be either a clear coat or a coloured preservative.

Timber Information.

As timber is a natural material, there are certain weather conditions that may affect the materials properties. In times of excessive dry spells the material may lose some of its internal moisture causing a certain degree of shrinkage on a panel and in periods of excessive rain there will be a certain amount of swelling throughout the wooden panels. This process can not be avoided. If you have problems with certain boards shrinking in dry spells try to decrease the amount of direct sunlight on the building or the amount of air passing over the building. During hot spells spray water directly onto the panels with the aid of a garden hose.

If in doubt of any aspect regarding the assembly, use or safety of your Heritage Log Store please contact us :

Help Line: (Normal Office Hours) 01829 261 121

Email: support@rowgar.co.uk

ROWLINSON GARDEN PRODUCTS LIMITED
Green Lane
Wardle, Nr. Nantwich
Cheshire
CW5 6BN
www.rowgar.co.uk

We constantly improve the quality of our products, occasionally the components may differ from the components shown and are only correct at time of printing. We reserve the right to change the specification of our products without prior notice.

2017 © Rowlinson Garden Products Ltd

ROWLINSON®
GARDEN PRODUCTS

Heritage Log Store

English SS403

Assembly Instructions

Before assembly

- We recommend that time is taken to read the instructions before starting assembly, then follow the easy step by step guide. The instruction sheet is only a guide to the assembly. Certain items may not be shown to scale.
- Check all components prior to assembly
- This product should be assembled by no less than two people
- Drill all components where indicated



Recommended tools for assembly

- Powered drill/screwdriver
- 2mm drill bit
- Crosshead driver bit
- Spirit level
- Sharp knife

No.	Components	Qty.
1	Floor	1
2	Left-hand side panel	1
3	Right-hand side panel	1
4	Back panel	1
5	Front frame (35 x 29 x 1350mm)	2
6	Front fascia	2
7	Roof (8 x 905 x 705mm)	1
8	Felt batten (29 x 29 x 905mm)	1
9	Roof felt roll	1
10	Side bargeboard	2
11	Front bargeboard	1

No.	Fixing kit	Qty.
12	50mm screw	17
13	30mm nails	34
14	10mm felt nails	36

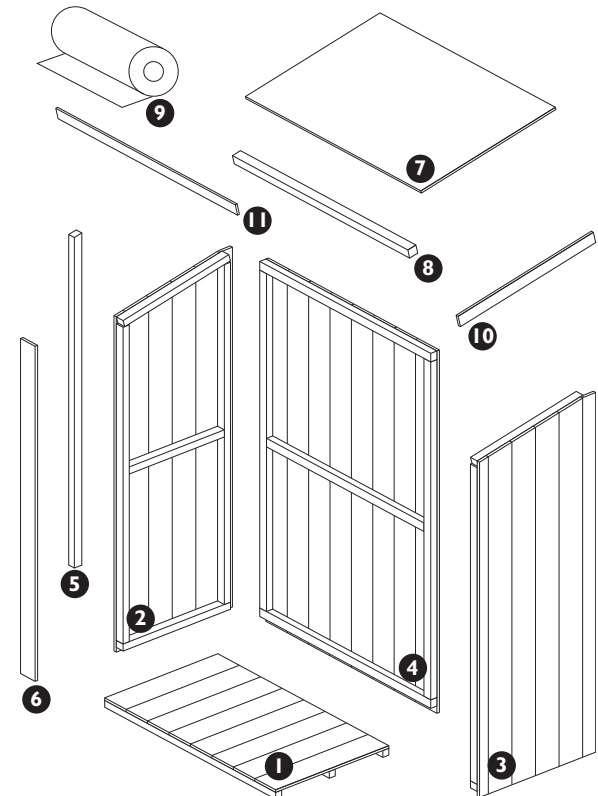
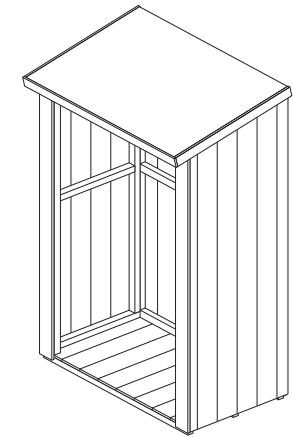

1. Floor

Prepare level area for the floor to sit. Attach three wooden or similar bearers of size 50 x 50 (Not supplied in kit) to the floor.

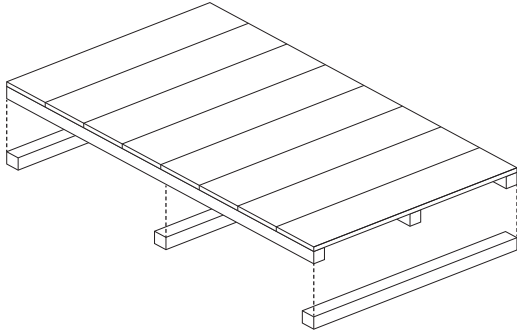

Important note

To "VALIDATE" the guarantee, adequate provision must be made to ensure ground contact is avoided and air is able to circulate underneath the building.

The building **MUST** be erected on pressure treated wooden 50mm x 50mm or similar bearers (These are not supplied in the kit).

2. Wall panels

Position the back panel and the left-hand side panel as shown. Note how the panel frames sit on the floor with the panel cladding overhanging the floor edge. Ensure square and secure using 3 x 50mm screws through the frame of the back panel, into the frame of the back panel. Secure the right-hand side panel in the same way.



Drill pilot hole for each screw in this section.

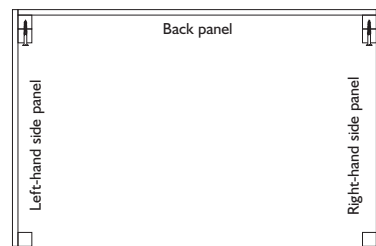
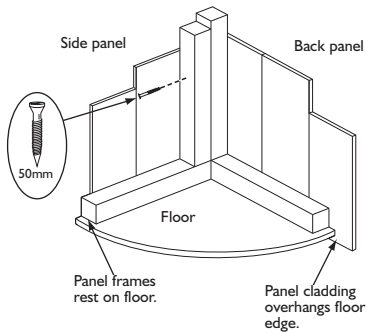
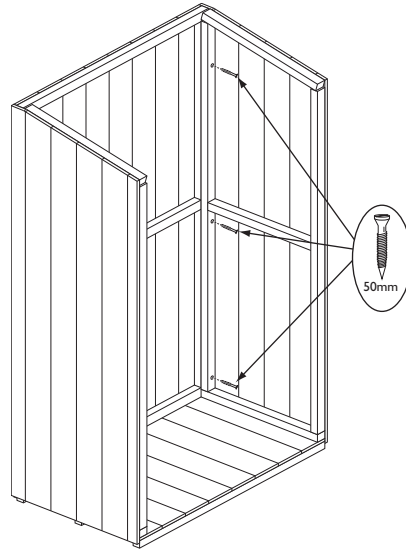
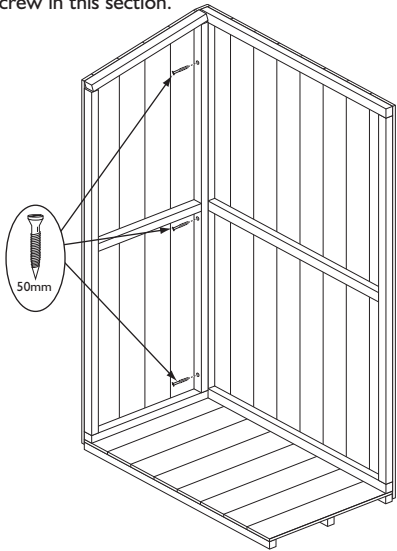

3. Front frame and fascia

Secure the front frame uprights to the framing of the side panels as shown using 3 x 50mm screws per upright. Ensure they are flush at the front with the side panel frames. Nail each front fascia to the front face of the side panel frame and front frame using 5 x 30mm nails per fascia.

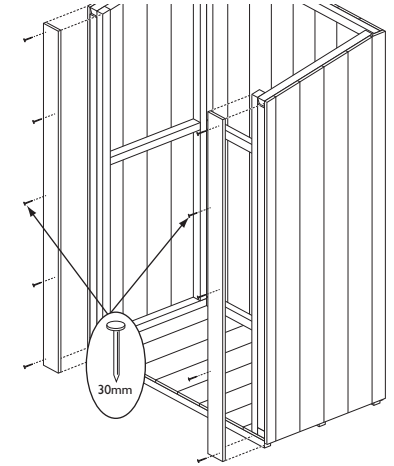
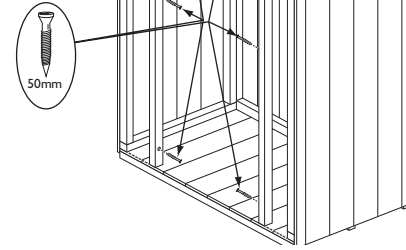

4. Secure walls to floor

Secure the back panel to the floor using 3 x 50mm screws. Screw through the bottom frame of the back panel into the floor. For each side panel fix to the floor using 1 x 50mm screw. Screw through the bottom frame of the side panels and floor boards into the centre floor frame.

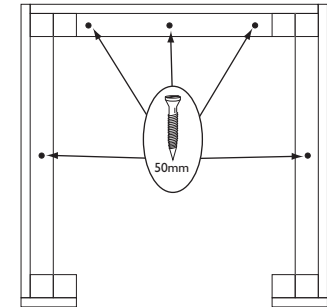
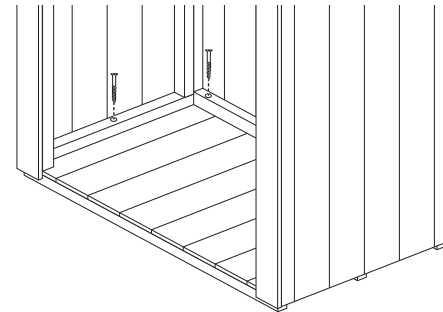

5. Roof

Fix the roof panel flush to the felt batten as shown, using 4 x 30mm nails, nail through the roof into the batten. Lift the roof onto the assembly with the felt batten at the front. Ensure the roof is flush at the sides and back of the store and secure in place using 8 x 30mm nails along the back and sides as shown below.

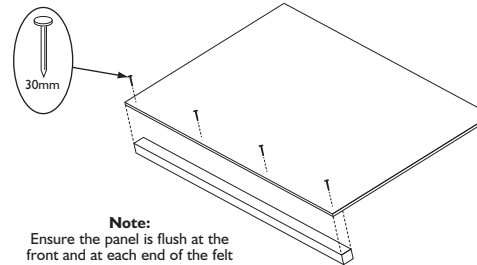

Note:
Ensure the panel is flush at the front and at each end of the felt batten.

