



# Smart AI Recognition Bird Feeder

## Product manual

# CONTENT

Warm tips.....	1
What's in the box.....	2
Specifications for bird feeder.....	3
Introduction for bird feeder.....	4
Introduction for camera.....	5
Indicator light.....	6
How to connect to the APP.....	7-11
APP interface introduction.....	12
Top cover installation.....	13
How to install.....	14-17
How to charge the camera.....	17
FAQ .....	18-21

## **WARM TIPS**

- 1.Keep the bird feeder and all accessories out of reach of children and pets.
- 2.Make sure the camera has been fully charged for the first time.
- 3.Please do not expose the camera lens to sunlight directly .
- 4.Please do not soak the bird feeder in water.
- 5.Please use 2.4 GHz WI-FI to connect the application.
- 6.Please stay away from the strong light when pairing.
- 7.Please keep the bord feeder within the range of WI-FI signal.

# WHAT'S IN THE BOX

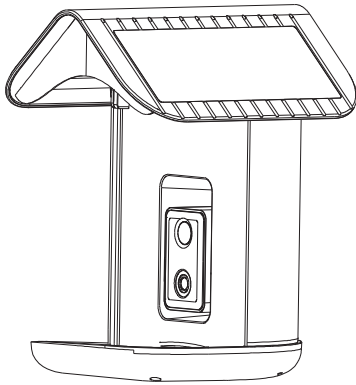

Bird feeder

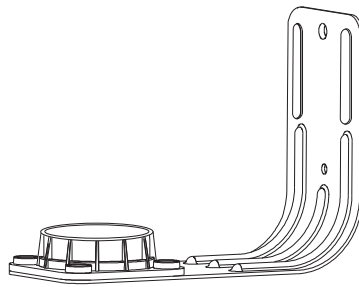

Bird feeder bracket

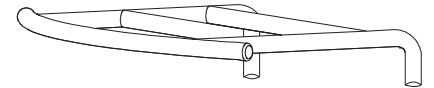

Perch



Drill Sticker

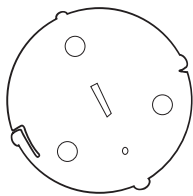

Bracket connector

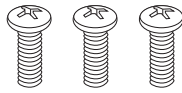

Screw\*3

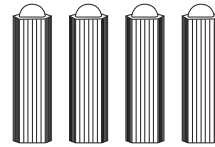

Green screws  
spacers \*4

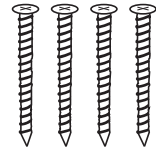

Screw for  
bracket \*4



Pin



Waterproof  
rubber

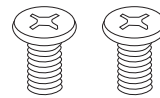

Screw for  
perch\*2

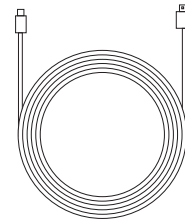

Charging cable

# SPECIFICATIONS FOR BIRD FEEDER

Product Model	BF11
Charging	Solar panel and USB cable
Battery	5200 mAh Rechargeable Lithium-Ion Battery
Resolution	2.0 MegaPixels Photos and 1080P HD Live Stream Video
Operating Temperature	-5°F to 120°F (-20.5°C to 48.5°C)
Wireless Type	WiFi 2.4GHz
Field of View	Diagonal: 130°, Horizontal: 94°, Vertical: 40°
Dimension	L7.64 * W8.46 * H12.40 inches (19.4 * 21.5 * 31.5cm)
Power Supply	DC 5V2A
Power Consumption	2W(Max.)
Battery Life	4-6 years
Night Visual Range	8m(Max)
Anti-flicker	50HZ /60HZ

## **SOLAR PANEL SPECIFICATION**

IPCE	19%
Working Voltage (Vmp)	5V±5%
Working Current (Imp)	400mA±5%
Open Circuit Voltage (VOC)	7.2V±5%
Short-Circuit Current (ISC)	480mA±5%

# INTRODUCTION FOR BIRD FEEDER

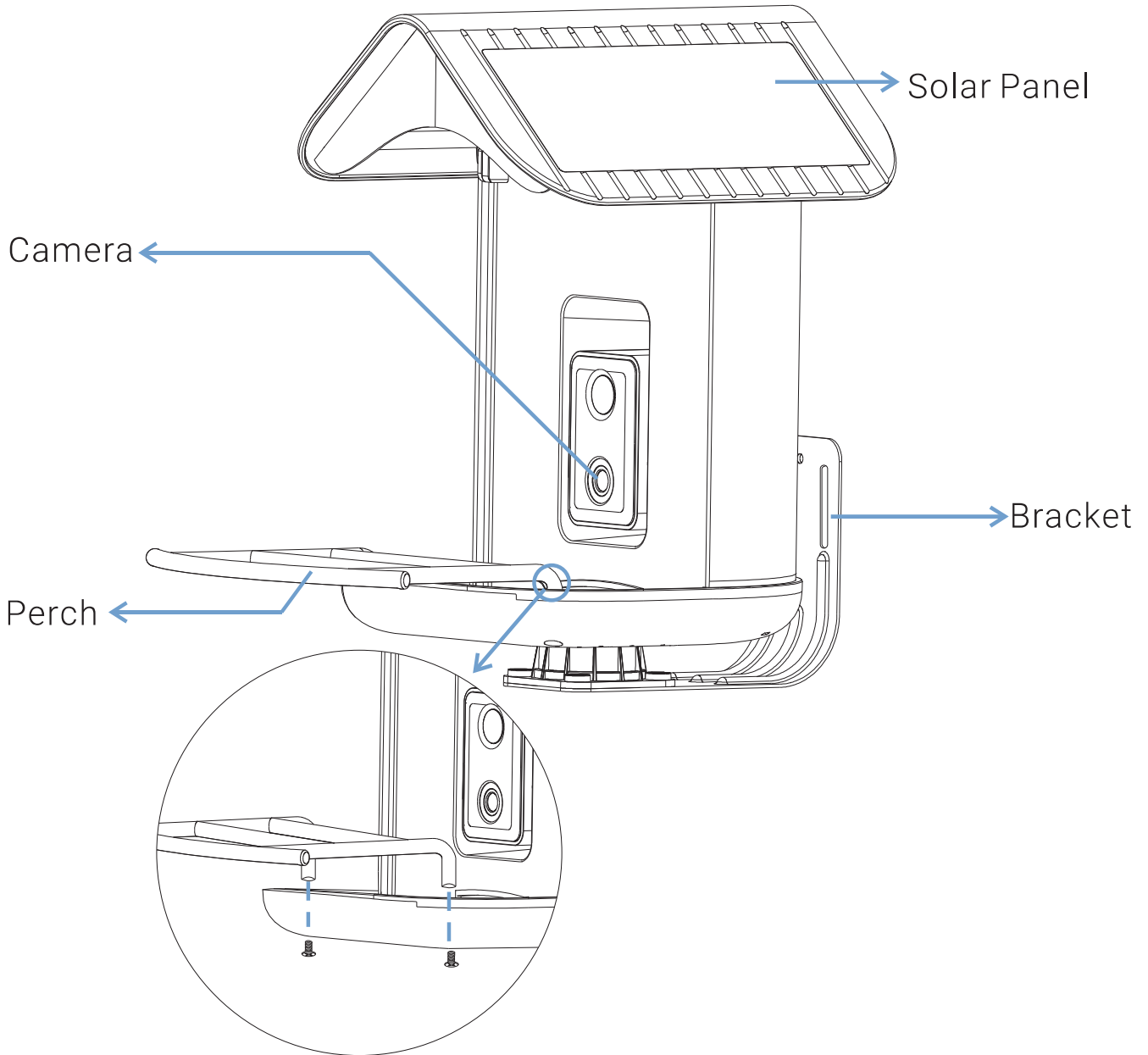

# INTRODUCTION FOR CAMERA

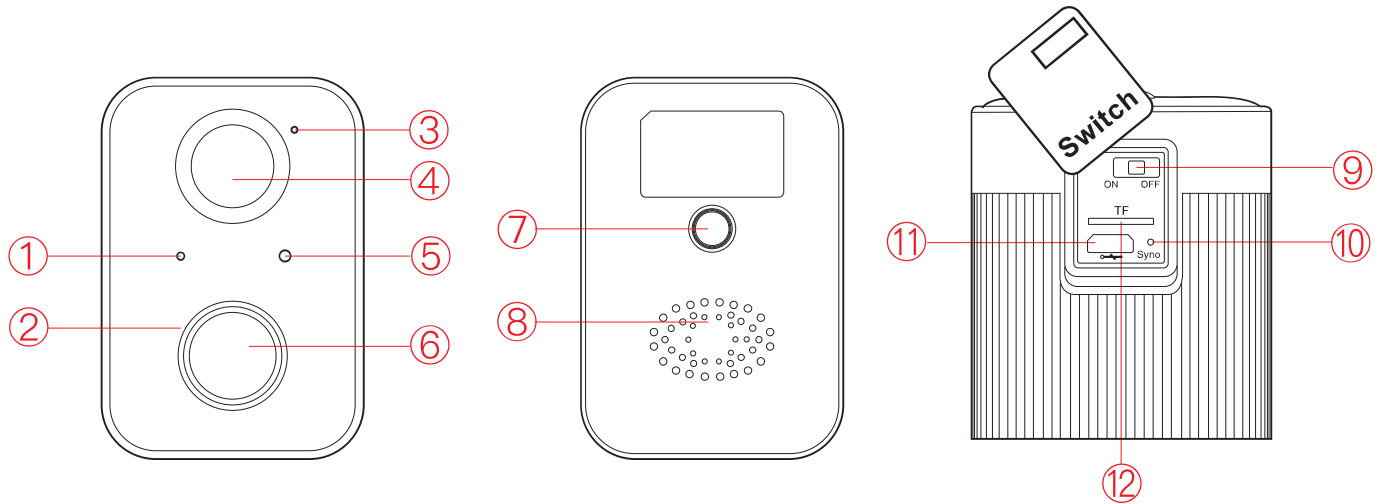

① Indicator Light

⑤ Light sensor

⑨ Power ON/OFF

② Infrared LED

⑥ Lens

⑩ Sync/Reset

③ Microphone

⑦ Mounting hole

⑪ Charging port

④ Motion sensor

⑧ Speaker

⑫ TF card slot (Capacity expansion 128G)

# INDICATOR LIGHT

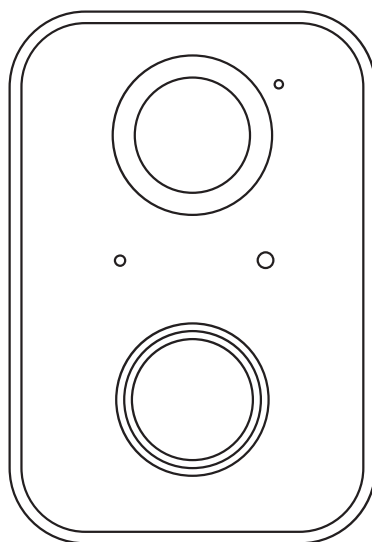

- 1.Camera turn on: Red light always ON.
- 2.Pairing mode: Red light fast blinking.
- 3.Network connecting: Green light fast blinking.
- 4.Network connected: Green light always ON.
- 5.Abnormal status : Red light slow blinking.(Need to reset)
- 6.During firmware update: Yellow light always ON.
- 7.Charging status: White light always ON during charging and OFF after fully charged.



# HOW TO CONNECT TO THE APP



Download or scan the QR code and install the Bird Lover App for either IOS or Android. Once downloaded, the APP will prompt you to register your device. Enter your phone number or email address which one makes you feel comfortable and select the country you live in. You will receive the registration code. Input the registration code, then create a password.

1. Turn on the power switch.

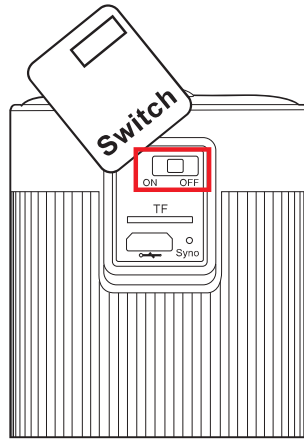

2. Open the APP and connect according to the following steps.

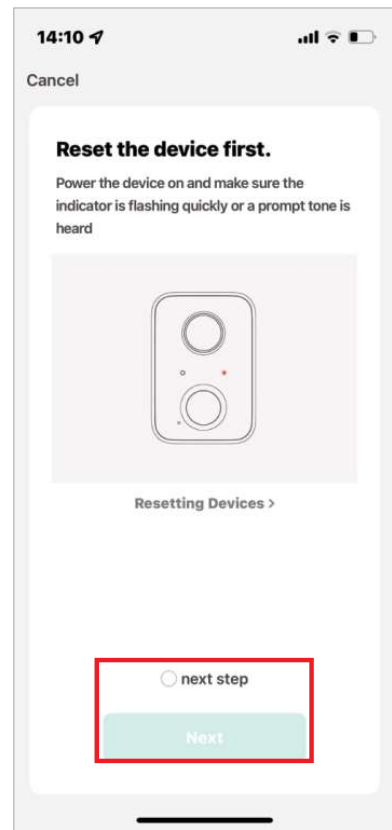
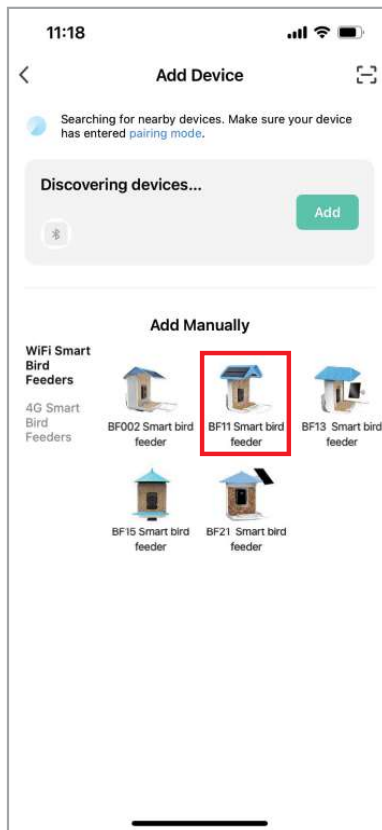
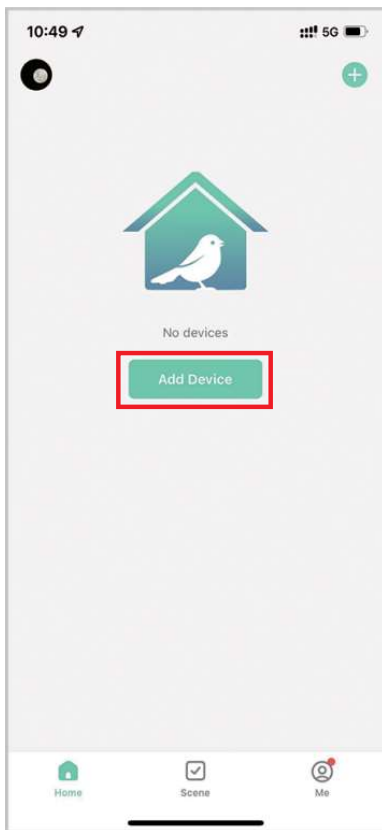

3. Enter the WIFI password.

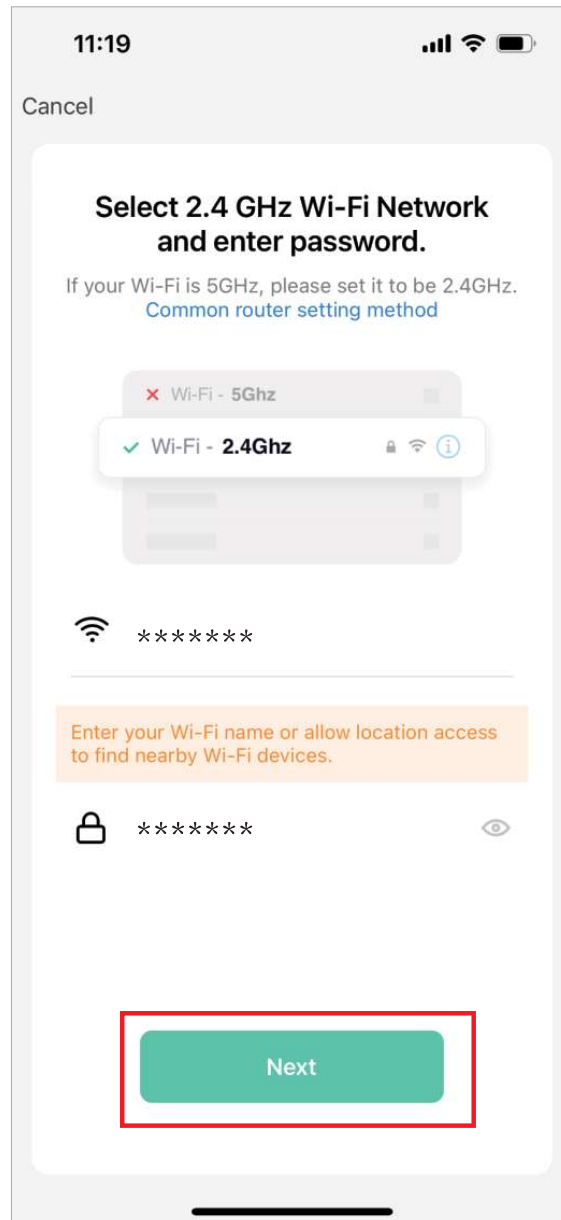

4. Scan the QR code with the camera, and enter the connection after hearing the sound of the camera prompt.

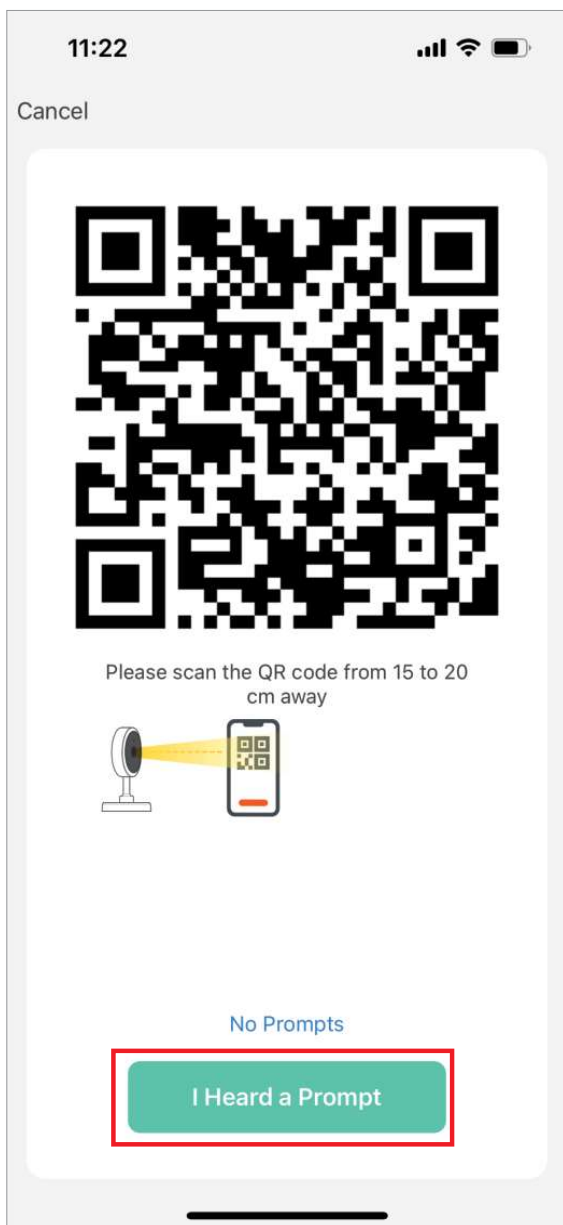

NOTE: The QR code needs to be aimed at the camera below

5. Wait for the connection to complete, and click "Done".

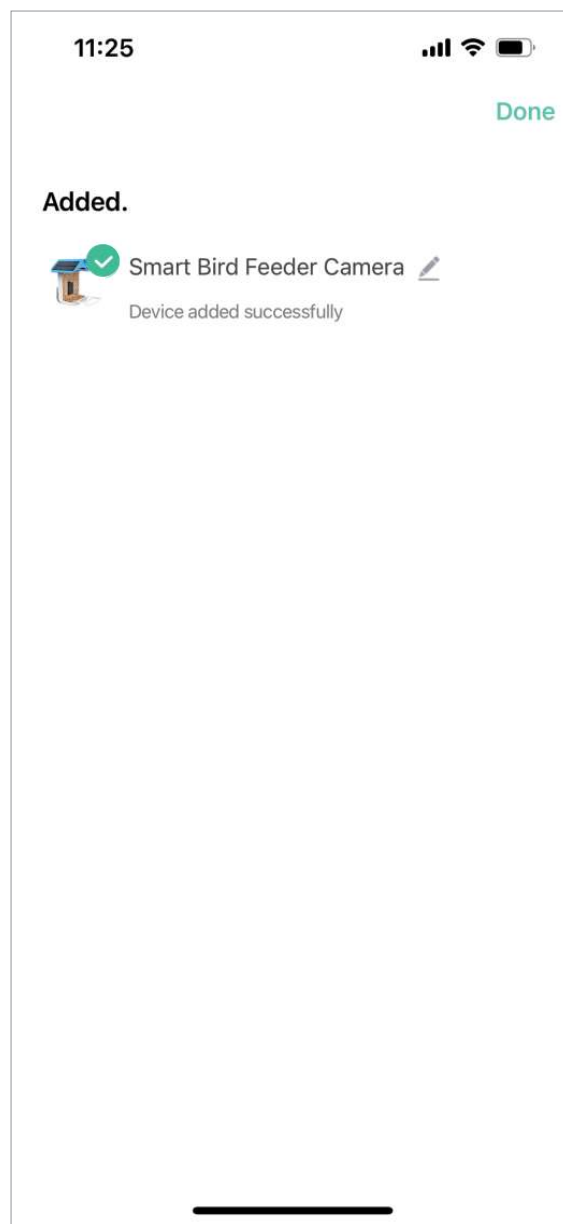
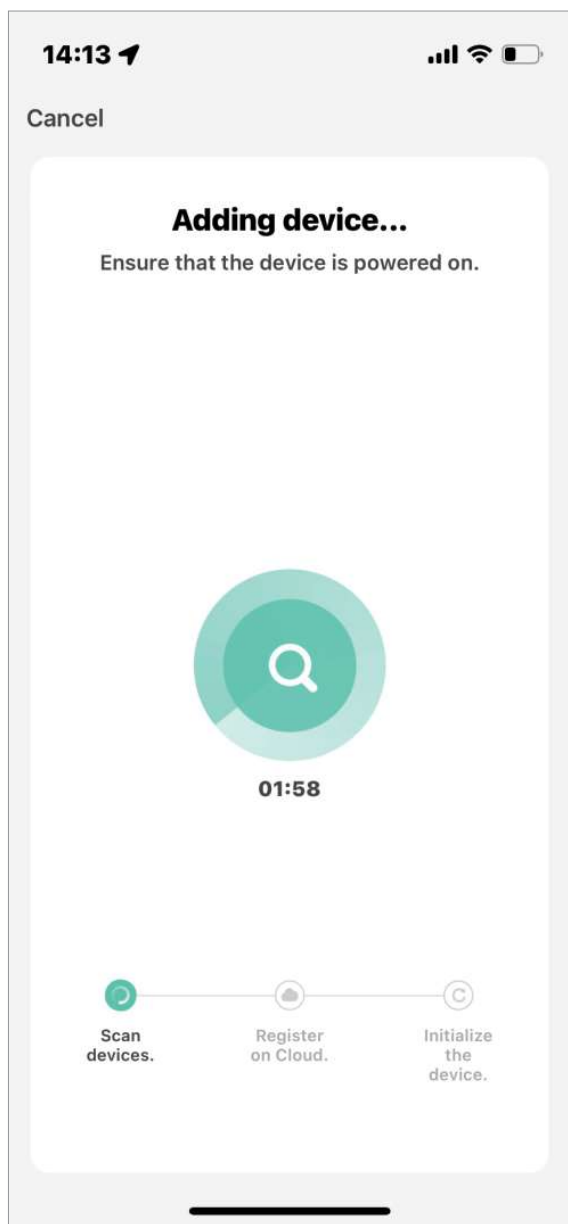

# APP INTERFACE INTRODUCTION

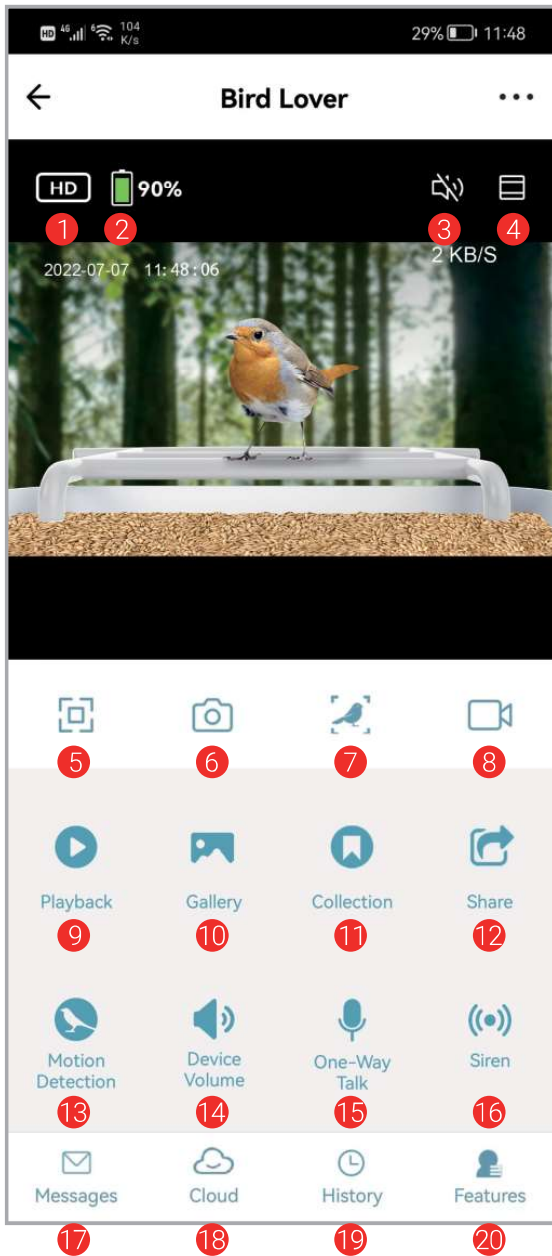

1. Quality adjustment: you can choose HD or SD
2. Battery Remaining Capacity
3. Voice switch
4. Zoom in the screen for camera
5. Screen horizontal and vertical adjustment
6. Take photo
7. Bird recognition
8. Shot videos
9. Playback for previous
10. View photos or videos took
11. Check out the bird collection
12. Share the device
13. Motion detection(Click to turn on/off)
14. Device Volume
15. One-Way Talk
16. Siren
17. Notification for motion detection
18. Cloud storage service
19. History for bird recognition
20. Back to all function interface

# TOP COVER INSTALLATION

1. Align the top cover with the groove of the birdhouse and press down.



2. Connect the battery charging cable to the top cover.



3. Twist and snap the top cover.



# HOW TO INSTALL

1. Stick the sticker on the tree or wall and drill holes within the range marked on the sticker.



2. Insert the green plastic screw spacers into the hole.





3. Fix the bracket with long screws.



4. Install the bird feeder and align the three holes underneath.



5. Fix bird feeder with three short screws.



6. Install the perch with the two screws in the package.



7.The bird house can rotate left and right.



## HOW TO CHARGE THE CAMERA

- ① Rotate the camera down.
- ② Connect the solar charging cable.
- ③ Or remove the camera and charge it with the charging cable.



①



②



③

# FAQ

Q: Do I need to create an account to use the App?

A: Yes, you need to use email address or phone number to get a verification code for registering an account .

Q: What operating systems are the App compatible with?

A: The App is compatible with Apple iOS and Android system.

- IOS 10.0 and above.
- Android V5.0 and above.

Q:What Wifi band does the AI Camera support?

A: 2.4Ghz WiFi only.

Q: How many accounts can be linked with one Smart Bird Feeder?

A: The Smart Bird Feeder can only be linked to one account at a time. If it is linked by other accounts, please Long press the reset button for 10s to release.

Q: Can I share the Smart Bird Feeder with other users?

A: Yes. You are able to share the Smart Bird Feeder with other users however they will need to install the “Bird Lover” app.

When the App is ready, any of the following methods is optional to share the device:

- When they have individual account:
  - 1.Sharing the device by adding the their account names.
  - 2.Adding new accounts to your family group.
- When they have no individual account:

Using your main account and password to log in the same way as you do.

**Q: What's the language of the App?**

A: The App's language will match your device's system language. But the Language of AI recognition result only supports English or Chinese now.

**Q: Why is the camera battery draining so fast?**

It is low power consumption camera. Plus the solar panel power in charge, it can maintains the daily energy consume in sunny day. If the batteny drains too fast you should check:

1. Whether you check the camera with APP too often.
2. Whether the camera always wakes up due to too many birds visiting.
3. Do the Wi-Fi performance is good or not? Once the camera lost Wi-Fi or Wi-Fi is too weak, the camera will scouring the Wi-Fi signal again and again, till the power used up.

**Q: Why the "Playback" is not available?**

A: Check the following:

1. Please confirm that the TF card is installed correctly or the payment action of cloud storage has been completed. If the TF card cannot be read, please format it to FAT32 with computer. Our product support 4G-128G TF card.
2. Please make sure you have enabled recording in the "Recording Settings" And turn on the detection mode.

**Q: How to turn on or turn off the message notify?**

A: 1. Enter the main page and find “Me” on the left bottom, click icon “🎯”  
And set the app notification to turn on or off “Enable Notifications”. You can also set up a schedule for “Do-Not Disturb Schedule” at the same interface.

2. Turn on or off the “Motion Detection” at the UI interface.

3. Turn on or off the “Detection Alarm Settings” on the Setting interface.

**Q: Why the recognition result is wrong?**

A: The accuracy rate depends on the angle and clarity of the bird image. To get more accurate result, please ensure the picture is clear enough. The identify features (bird’s head, tail wings and pattern of feathers) should not be obscured. The bird image should be shown in the main position of the picture.

Retry to capture more clear bird photos in the movement to recognize the bird if the result is not satisfied.

If there are two or more bird species in one picture, the recognized result will focus on the main position.



Demonstration: The best angle for recognition

Q: What should I do if the device is not working properly?

1. Please check whether the power cable is correct plugged in and make sure the power switch is turned on.
2. Please check whether the WI-FI is available and the smart bird feeder is work at the range of WI-FI.
3. Please remove the device and reconnect it.

