

# 253480 Table forestiere / Combined table

## 165x150xh76cm

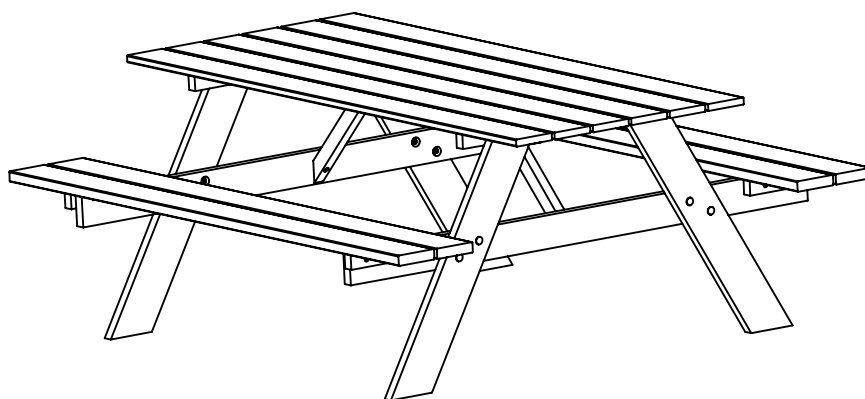

Traité en autoclave, en  
pin d'Europe du Nord.  
A monter soi-même

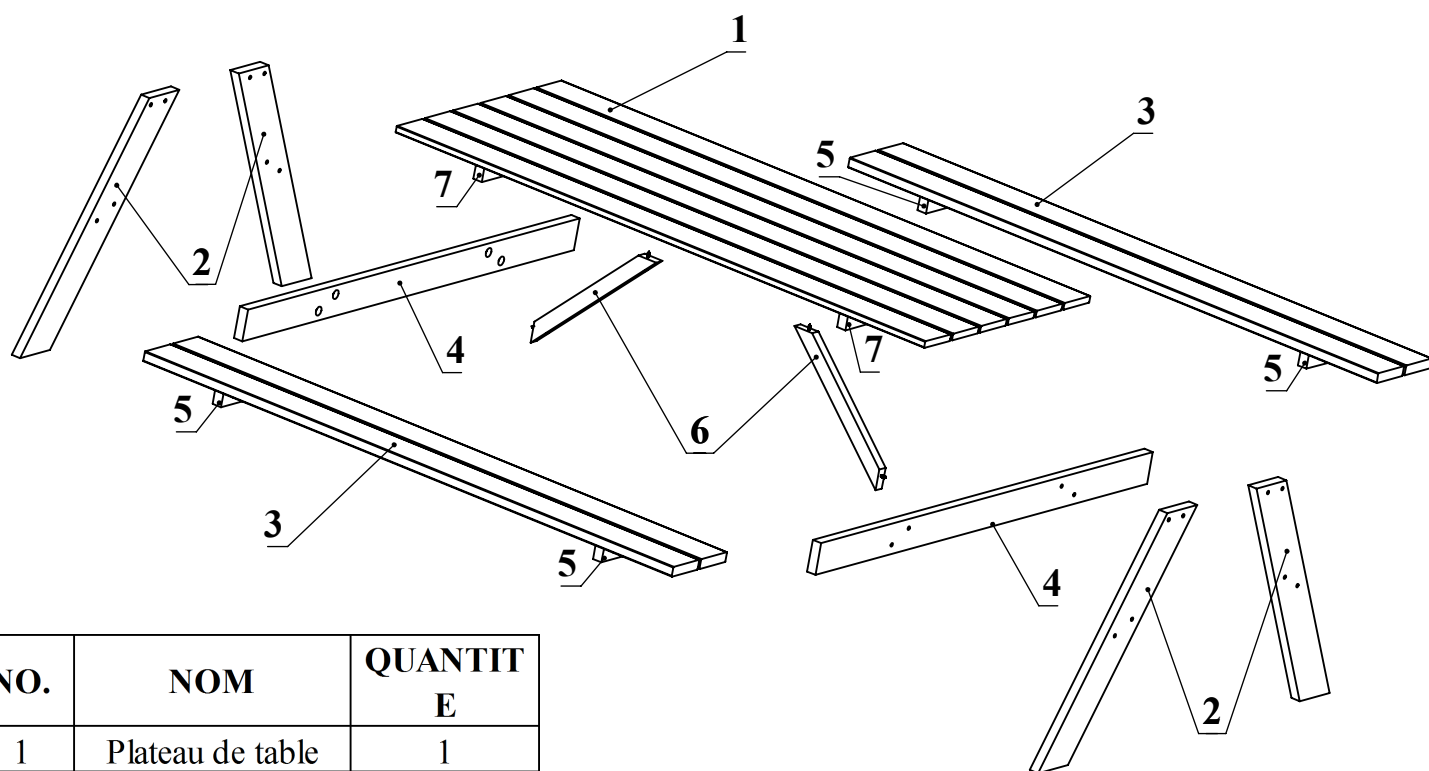

NO.	NOM	QUANTIT E
1	Plateau de table	1
2	Pieds de table	4
3	Assise de banc	2
4	Longues barrièrs	2
5	Barrièrs banc	4
6	Elements de connexion	2
7	Supports banc	2
8	Vis 4.5x35	4
9	Boulons bloquants M8x60	16
10	Rondelles M8	16
11	Ecrous M8	16
12	VIS 5x50	8

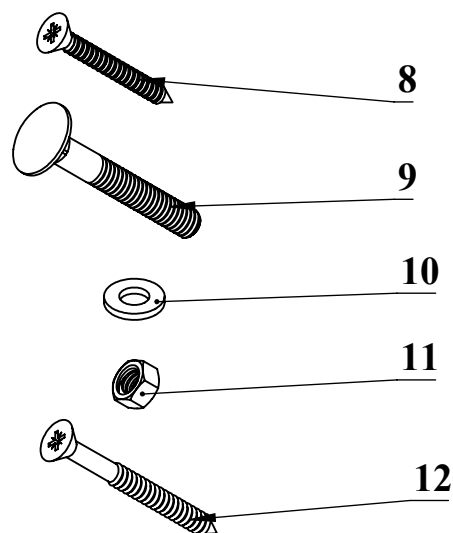

# 253480 Table forestiere 165x150xh76cm

1.

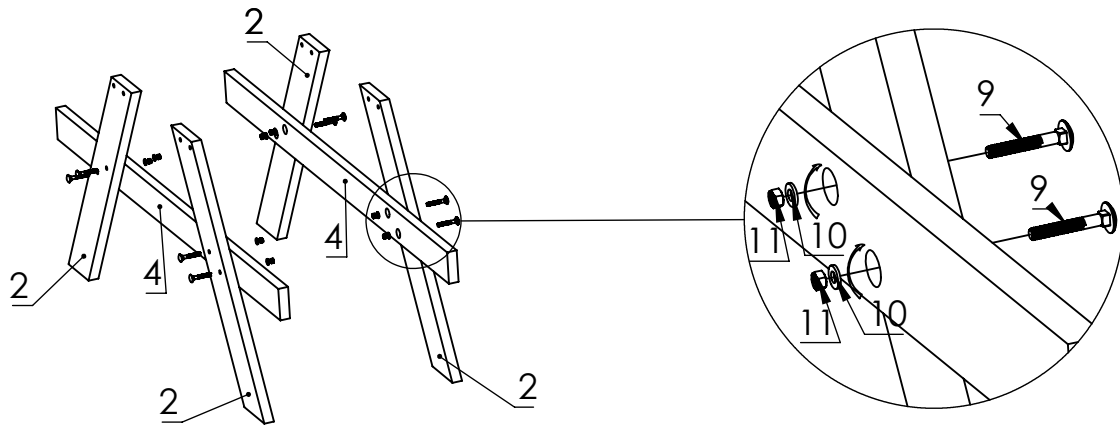

2.

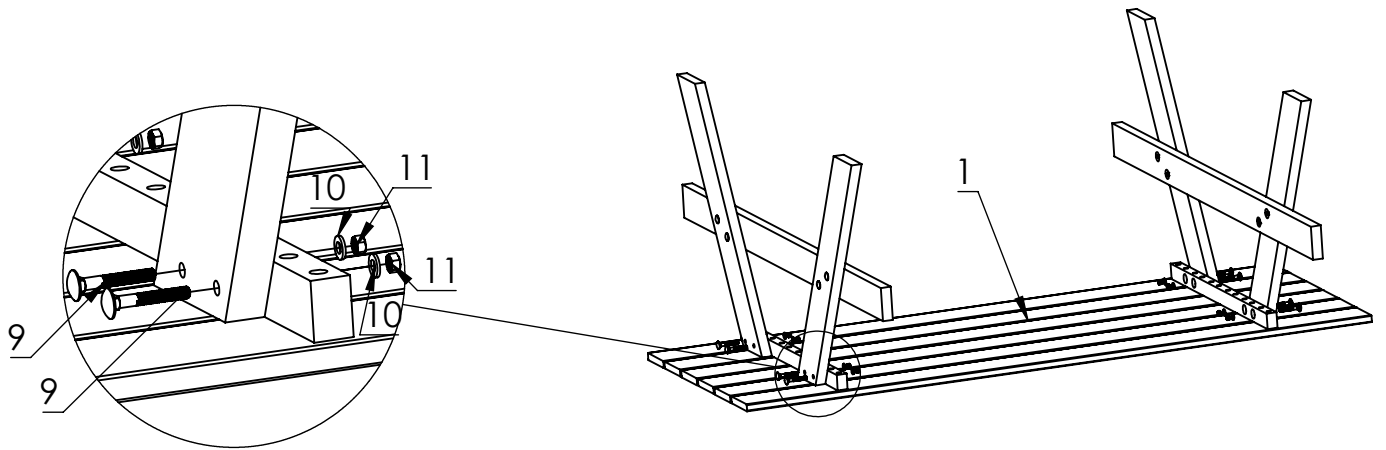

3.

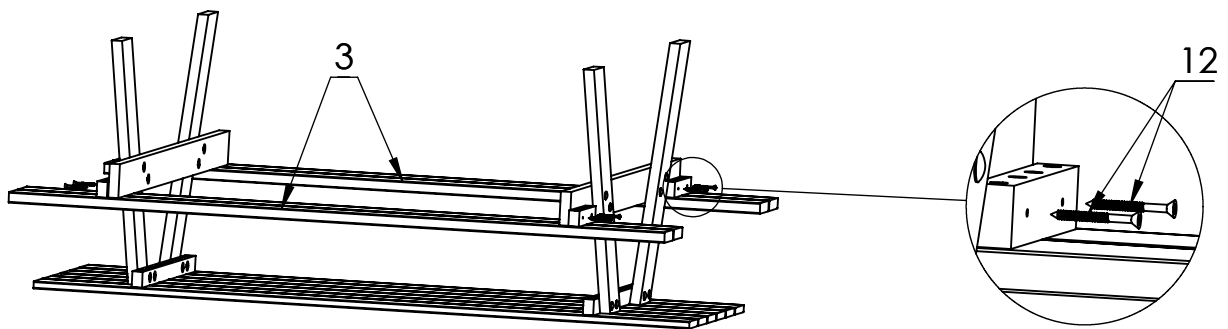

4.

